

Features

- 600V Field Stop Trench Technology
- High Speed Switching
- Low Conduction Loss
- Positive Temperature Coefficient
- Easy Parallel Operation
- Short Circuit Withstanding Time 5 μ s
- 175 $^{\circ}$ C Operating Temperature
- RoHS Compliant
- JEDEC Qualification

TO-247

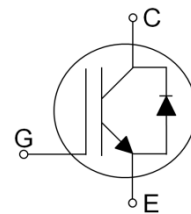

Applications

Motor Drive, Air Conditioner, Inverter, Solar

Device	Package	Marking	Remark
TGH30N60FDRSH	TO-247	TGH30N60FDRSH	RoHS

Absolute Maximum Ratings

Parameter	Symbol	Value	Unit
Collector-Emitter Voltage	V_{CES}	600	V
Gate-Emitter Voltage	V_{GES}	± 20	V
Continuous Collector Current	I_C	$T_C = 25^{\circ}C$	60
		$T_C = 100^{\circ}C$	30
Pulsed Collector Current (Note 1)	I_{CM}	90	A
Diode Continuous Forward Current	I_F	30	A
Power Dissipation	P_D	$T_C = 25^{\circ}C$	230
		$T_C = 100^{\circ}C$	115
Operating Junction Temperature	T_{vj}	-55 ~ 175	$^{\circ}C$
Storage Temperature Range	T_{STG}	-55 ~ 150	$^{\circ}C$
Maximum lead temperature for soldering purposes, 1/8" from case for 5 seconds	T_L	300	$^{\circ}C$

Notes :

- (1) Repetitive rating : Pulse width limited by maximum junction temperature , During production, high current switching capability is 100% verified with the inductive load single-pulse switching test. ($I_C=90A$)

Thermal Characteristics

Parameter	Symbol	Value	Unit
Maximum Thermal resistance, Junction-to-Case	$R_{\theta JC}$ (IGBT)	0.65	$^{\circ}C/W$
Maximum Thermal resistance, Junction-to-Case	$R_{\theta JC}$ (DIODE)	2.00	$^{\circ}C/W$
Maximum Thermal resistance, Junction-to-Ambient	$R_{\theta JA}$	40	$^{\circ}C/W$

Electrical Characteristics of the IGBT $T_{vj}=25^{\circ}\text{C}$, unless otherwise noted

Parameter	Symbol	Test condition	Min.	Typ.	Max.	Unit
OFF						
Collector – Emitter Breakdown Voltage	BV_{CES}	$V_{GE} = 0V, I_C = 1mA$	600	--	--	V
Zero Gate Voltage Collector Current	I_{CES}	$V_{CE} = 600V, V_{GE} = 0V$	--	--	1	mA
Gate – Emitter Leakage Current	I_{GES}	$V_{CE} = 0V, V_{GE} = \pm 20V$	--	--	± 250	nA
ON						
Gate – Emitter Threshold Voltage	$V_{GE(TH)}$	$V_{GE} = V_{CE}, I_C = 30mA$	4.5	6.0	7.5	V
Collector – Emitter Saturation Voltage	$V_{CE(SAT)}$	$V_{GE} = 15V, I_C = 30A, T_{vj} = 25^{\circ}\text{C}$	--	1.80	2.30	V
		$V_{GE} = 15V, I_C = 30A, T_{vj} = 125^{\circ}\text{C}$	--	2.20	--	
		$V_{GE} = 15V, I_C = 30A, T_{vj} = 175^{\circ}\text{C}$	--	2.40	--	
DYNAMIC						
Input Capacitance	C_{IES}	$V_{CE} = 30V,$ $V_{GE} = 0V$ $f = 1MHz$	--	1080	--	pF
Output Capacitance	C_{OES}		--	80	--	
Reverse Transfer Capacitance	C_{RES}		--	55	--	
SWITCHING (Note 2)						
Turn-On Delay Time	$t_{d(on)}$	$V_{CC} = 400V, I_C = 30A$ $R_G = 10\Omega, V_{GE} = 15V$ Inductive Load, $T_{vj} = 25^{\circ}\text{C}$	--	26	--	ns
Rise Time	t_r		--	32	--	ns
Turn-Off Delay Time	$t_{d(off)}$		--	130	--	ns
Fall Time	t_f		--	24	36	ns
Turn-On Switching Loss	E_{ON}		--	0.78	1.17	mJ
Turn-Off Switching Loss	E_{OFF}		--	0.56	0.84	mJ
Total Switching Loss	E_{TS}		--	1.34	2.01	mJ
Turn-On Delay Time	$t_{d(on)}$	$V_{CC} = 400V, I_C = 30A$ $R_G = 10\Omega, V_{GE} = 15V$ Inductive Load, $T_{vj} = 175^{\circ}\text{C}$	--	27	--	ns
Rise Time	t_r		--	34	--	ns
Turn-Off Delay Time	$t_{d(off)}$		--	145	--	ns
Fall Time	t_f		--	46	--	ns
Turn-On Switching Loss	E_{ON}		--	1.27	1.90	mJ
Turn-Off Switching Loss	E_{OFF}		--	0.86	1.29	mJ
Total Switching Loss	E_{TS}		--	2.13	3.19	mJ
Total Gate Charge	Q_g	$V_{CC} = 400V, I_C = 30A$ $V_{GE} = 15V$	--	102	153	nC
Gate-Emitter Charge	Q_{ge}		--	10	15	
Gate-Collector Charge	Q_{gc}		--	61	91	
Short Circuit Withstanding Time	t_{SC}	$V_{CC} = 300V, V_{GE} = 15V, T_{vj} = 125^{\circ}\text{C}$	5	--	--	μs

Notes :

(2) Not subject to production test – verified by design/characterization

Electrical Characteristics of the DIODE $T_{vj}=25^{\circ}\text{C}$, unless otherwise noted

Parameter	Symbol	Test condition	Min.	Typ.	Max.	Unit
Diode Forward Voltage	V_{FM}	$I_F = 30\text{A}, T_{vj} = 25^{\circ}\text{C}$	--	2.25	--	V
		$I_F = 30\text{A}, T_{vj} = 175^{\circ}\text{C}$	--	2.10	--	V
Reverse Recovery Time	t_{rr}	$I_F = 30\text{A},$ $di/dt = 200\text{A}/\mu\text{s},$ $T_{vj} = 25^{\circ}\text{C}$	--	67	--	ns
Reverse Recovery Current	I_{rr}		--	5.1	--	A
Reverse Recovery Charge	Q_{rr}		--	202	--	nC
Reverse Recovery Time	t_{rr}	$I_F = 30\text{A},$ $di/dt = 200\text{A}/\mu\text{s},$ $T_{vj} = 175^{\circ}\text{C}$	--	150	--	ns
Reverse Recovery Current	I_{rr}		--	8.8	--	A
Reverse Recovery Charge	Q_{rr}		--	904	--	nC

IGBT Characteristics

Figure 1. IGBT Output Characteristics

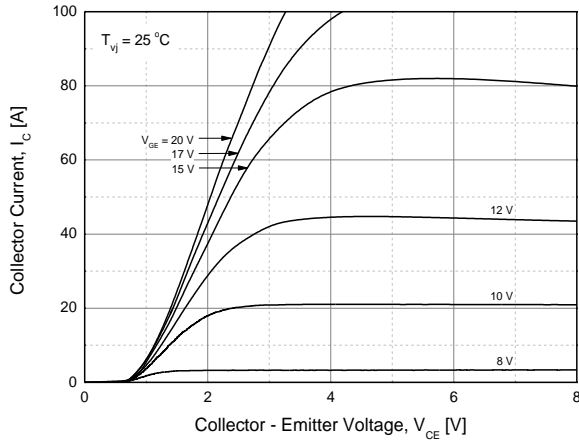

Figure 2. IGBT Output Characteristics

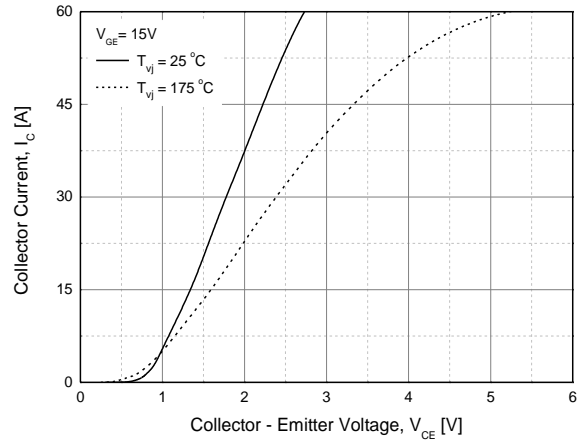

Figure 3. IGBT Saturation Voltage vs. Junction Temperature

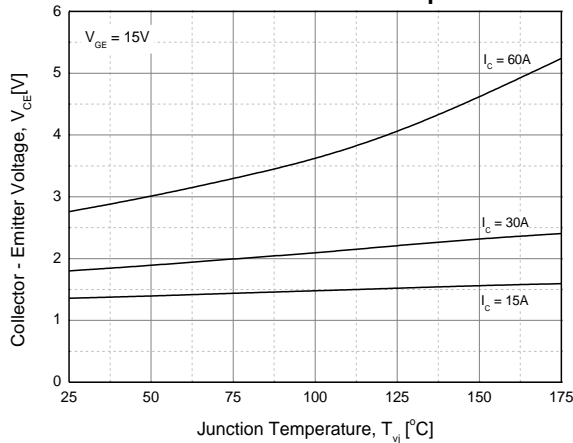

Figure 4. IGBT Saturation Voltage vs. Gate Bias

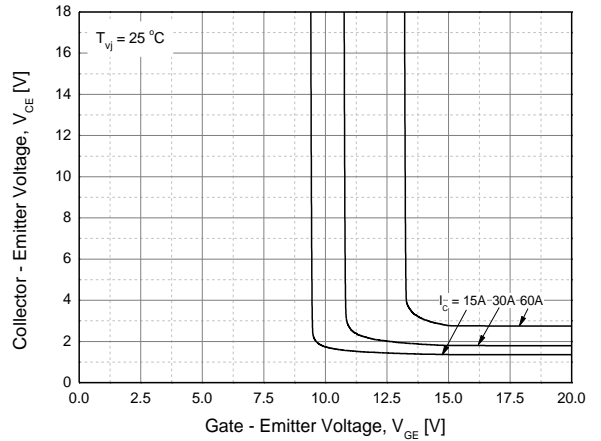

Figure 5. IGBT Saturation Voltage vs. Gate Bias

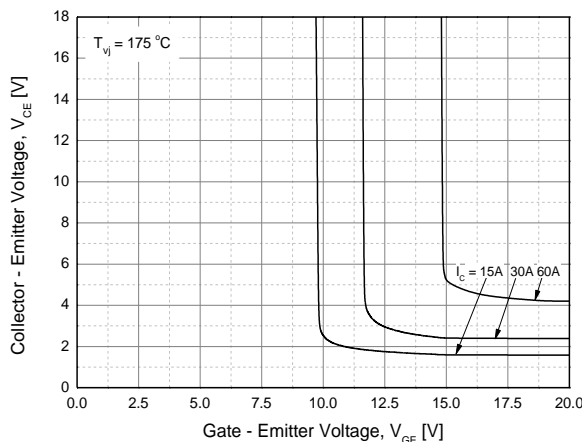
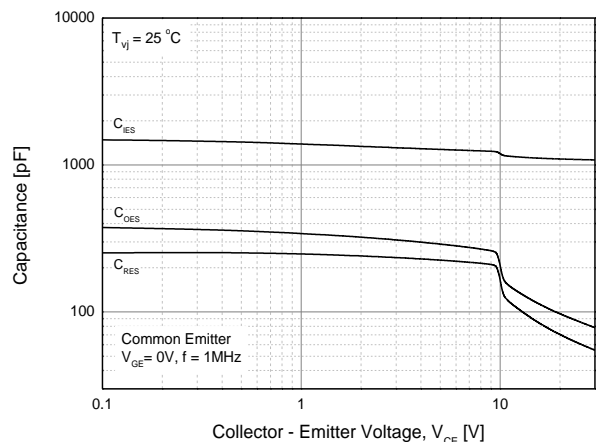

Figure 6. IGBT Capacitance Characteristics



IGBT Characteristics

Figure 7. Turn-on Time vs. Gate Resistor

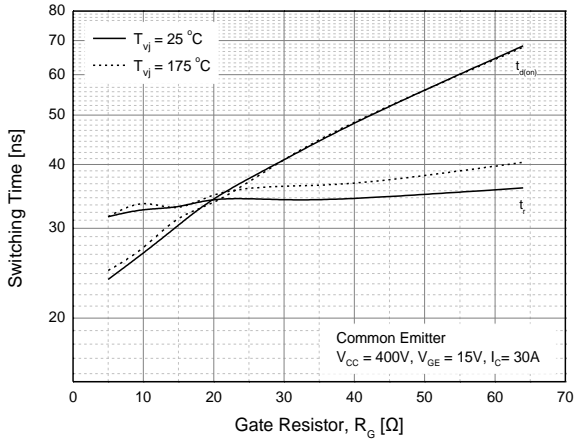

Figure 8. Turn-off Time vs. Gate Resistor

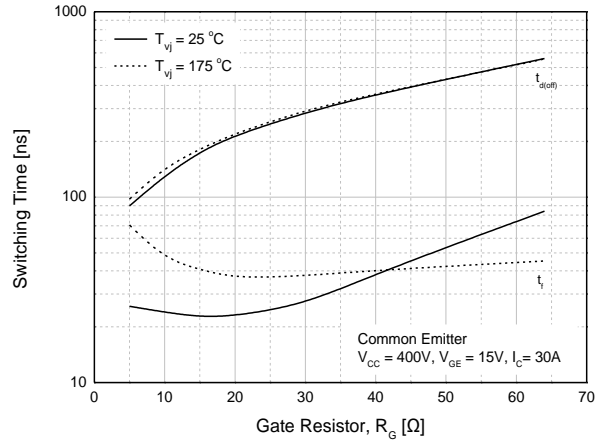

Figure 9. Switching Loss vs. Gate Resistor

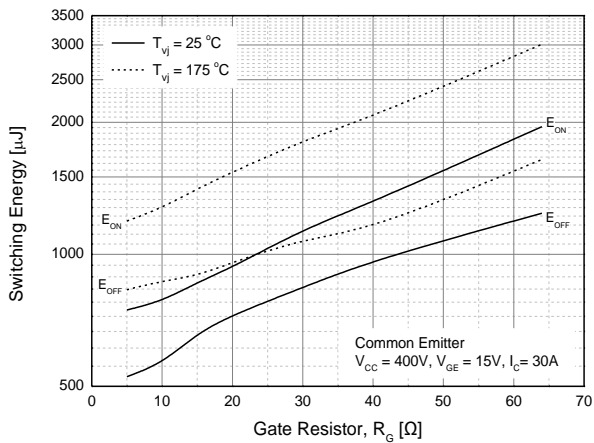

Figure 10. Turn-on Time vs. Collector Current

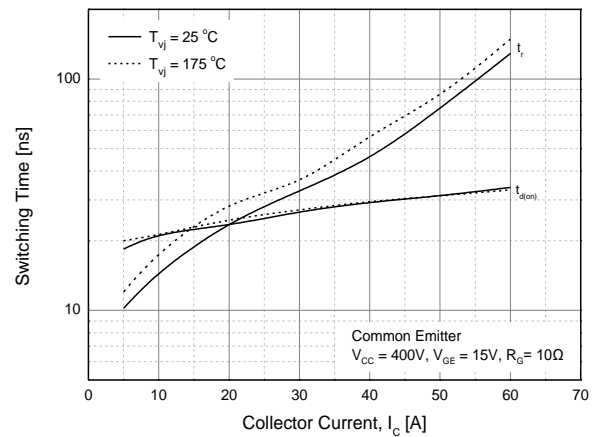

Figure 11. Turn-off Time vs. Collector Current

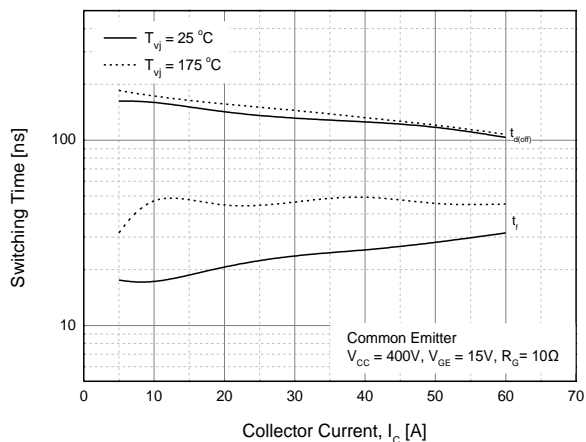
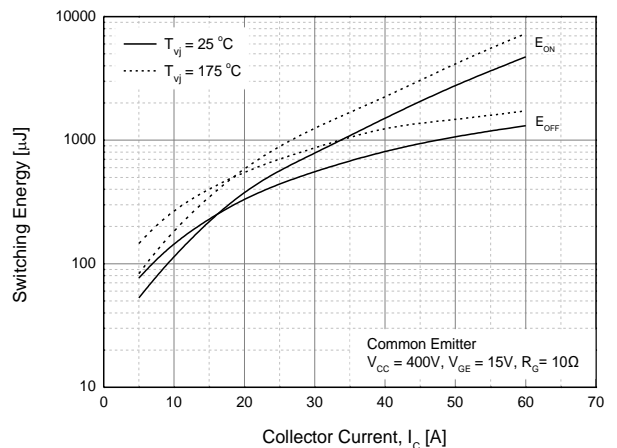

Figure 12. Switching Loss vs. Collector Current



IGBT Characteristics

Figure 13. Gate Charge Characteristics

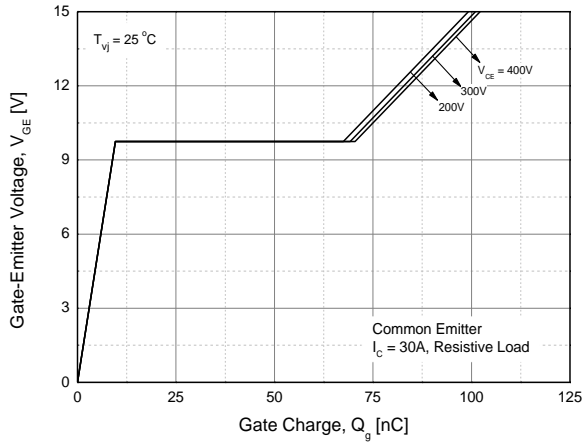

Figure 14. SOA

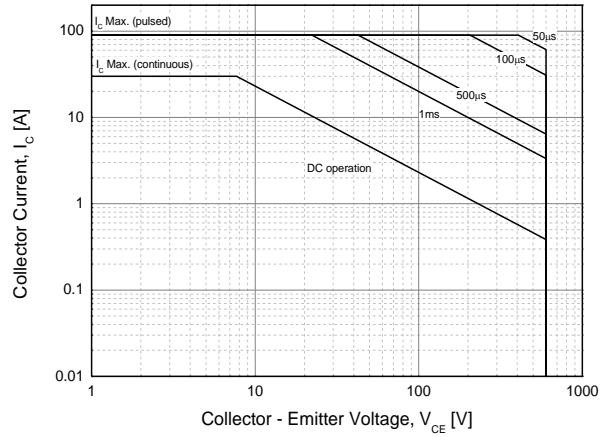

Figure 15. RBSOA

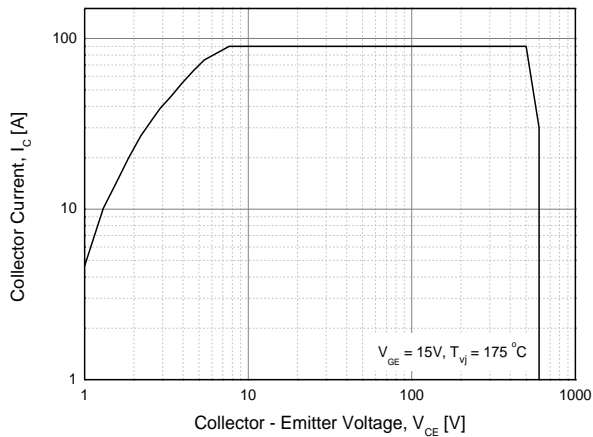

Figure 16. Transient Thermal Impedance of IGBT

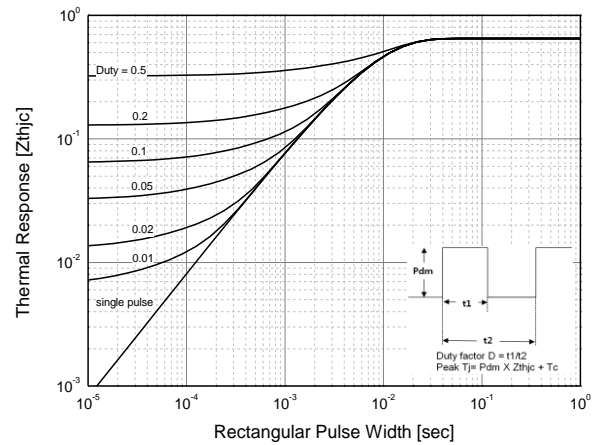
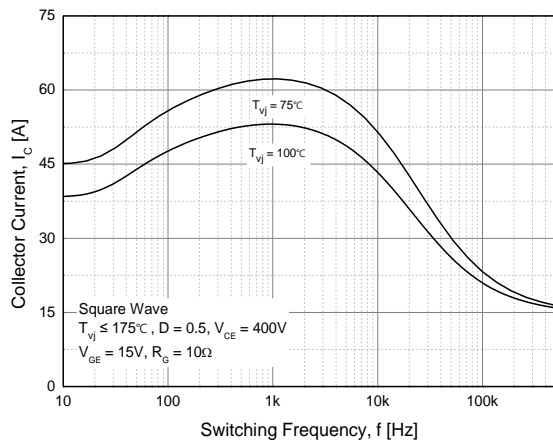

Figure 17. Load Current vs. Frequency



DIODE Characteristics

Figure 18. Diode Conduction Characteristics

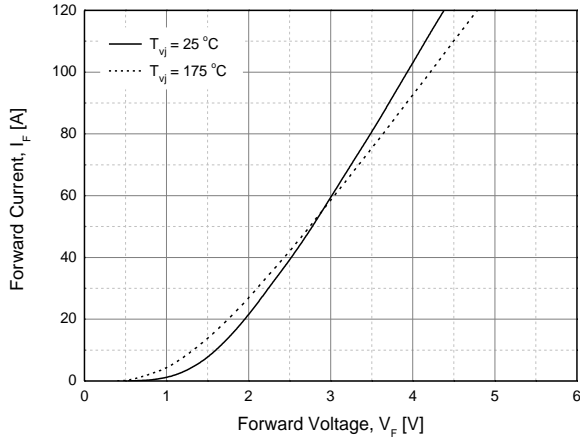

Figure 19. Reverse Recovery Current vs. Forward Current

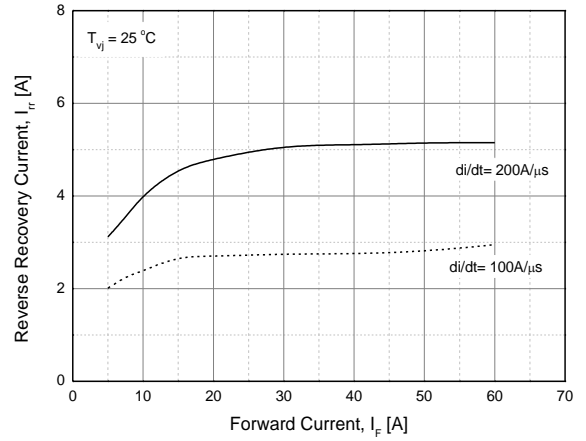

Figure 20. Reverse Recovery Charge vs. Forward Current

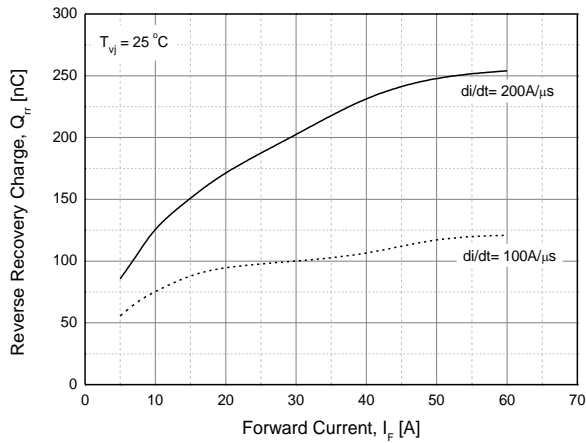
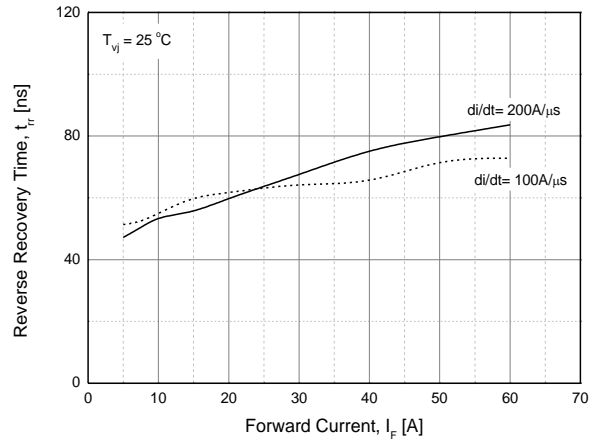
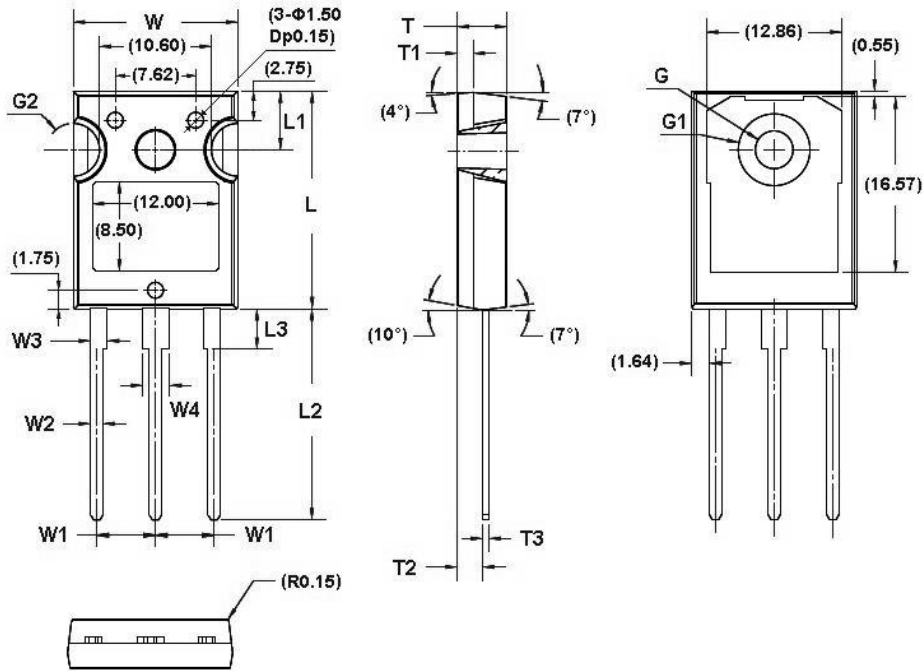

Figure 21. Reverse Recovery Time vs. Forward Current



TO-247 MECHANICAL DATA



SYMBOL	mm	
	Min	Max
W	15.4	15.8
W1	5.56 (TYP)	
W2	1.17	1.35
W3	1.55	1.75
W4	2.44	2.64
L	20.4	20.8
L1	5.36	5.56
L2	19.8	20.2
L3	3.69	3.93
T	4.6	4.8
T1	1.4	1.6
T2	2.3	2.5
T3	0.51	0.69
G(Φ)	3.51	3.65
G1(Φ)	6.61	6.85
G2(Φ)	4.96	5.2

Disclaimer :

TRinno technology reserves the right to make changes without notice to products herein to improve reliability, performance, or design. The information given in this document is believed to be accurate and reliable. However, it shall in no event be regarded as a guarantee of conditions and characteristics. With respect to any information regarding the application of the device, TRinno technology hereby disclaims any and all warranties and liabilities of any kind, including without limitation, warranties of non-infringement of patent rights of any third party.